



TPM

Permanent load lifting magnet

Capacity

100 - 3000 kg (Flat material)

50 - 1500 kg (Round material)

TPM load lifting magnets are ideal tools for easy, quick and thus economical transport of heavy objects made of ferro-magnetic material. Typical operating areas are workshops and warehouses, loading and unloading of machines as well as construction of jigs and fixtures.

Compact design of the units for a large number of applications.

The load is not affected mechanically which allows lifting of flat as well as round material. The efficient magnet body provides strong lifting capacity at low dead weight. The permanent magnets do not require electric energy and will leave only minor residual magnetism on the material after use.

The magnets are activated/deactivated easily by turning a locking lever. In activated condition the hand lever will be safely locked and thus prevent unintended demagnetising.

The selection of the appropriate magnet model should be made under consideration of the varying conditions of the contact surface, kind of material alloy and plate thickness/ bar diameter (see table).

INFO

In order to achieve a maximum capacity, the contact surface should be bright and free from dirt, oil, grease, scale, corrosion, paint etc.



Technical data TPM

Model	Art.-No.	Flat material			Round material			Test load	Weight
		Capacity ¹ max.	Material thickness min. at max. capacity	Length of material max.	Capacity ¹ max.	Diameter min. - max.	Length of material max.		
		kg	mm	mm	kg	mm	mm	kg	kg
TPM 0,1	N56400001	100	14	2000	50	40 - 300	2000	300	5.3
TPM 0,3	N56400002	300	20	2500	150	60 - 300	2500	900	13.5
TPM 0,5	N56400003	500	24	3000	250	60 - 400	3000	1500	27.5
TPM 0,8	N56400004	800	34	3500	400	60 - 400	3500	2400	52.0
TPM 1,0	N56400005	1000	40	3500	500	80 - 400	3500	3000	57.0
TPM 2,0	N56400006	2000	55	3500	1000	100 - 400	3500	6000	125.0
TPM 3,0	192019927	3000	65	3500	1500	200 - 500	3500	9000	195.0

¹gemessen auf ziehblankem Material S 235 JR (ST 37), Luftspalt < 0,1 mm

Dimensions TPM

Model	TPM 0,1	TPM 0,3	TPM 0,5	TPM 0,8	TPM 1,0	TPM 2,0	TPM 3,0
A, mm	122	192	232	302	332	392	497
B, mm	69	95	120	154	154	196	220
C, mm	185	225	270	320	320	420	453
D, mm	160	250	250	450	450	450	600

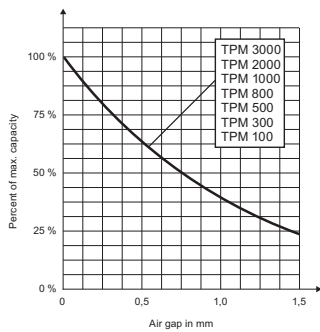

Diagram: WLL/air gap

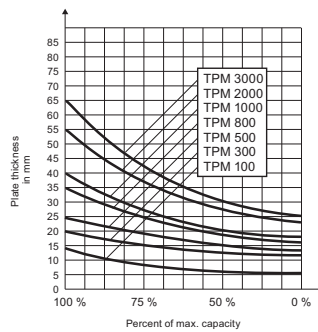
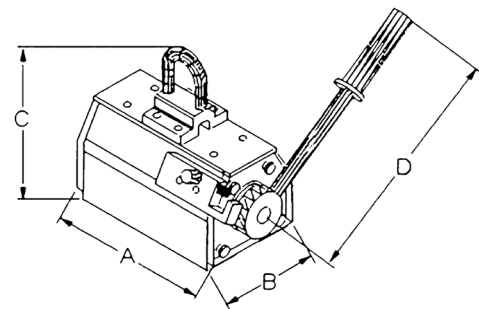
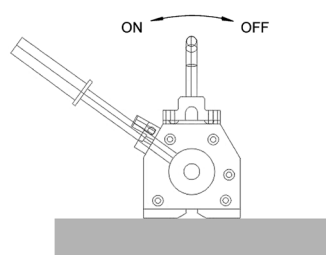

Diagram: WLL/material thickness



TPM



Correct use On/Off

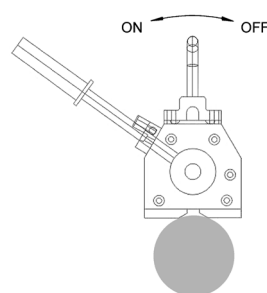

Reduction of capacity	% of capacity
Temperature ≤ 60°C	100 %
Humidity ≤ 80 %	100 %
St 52	95 %
Alloy steel	80 %
High carbon steel	70 %
Cast iron	45 %
Nickel	10 %
Austenitic, stainless steel	0 %
Brass	0 %
Aluminium	0 %

