

Product number: IN-2108

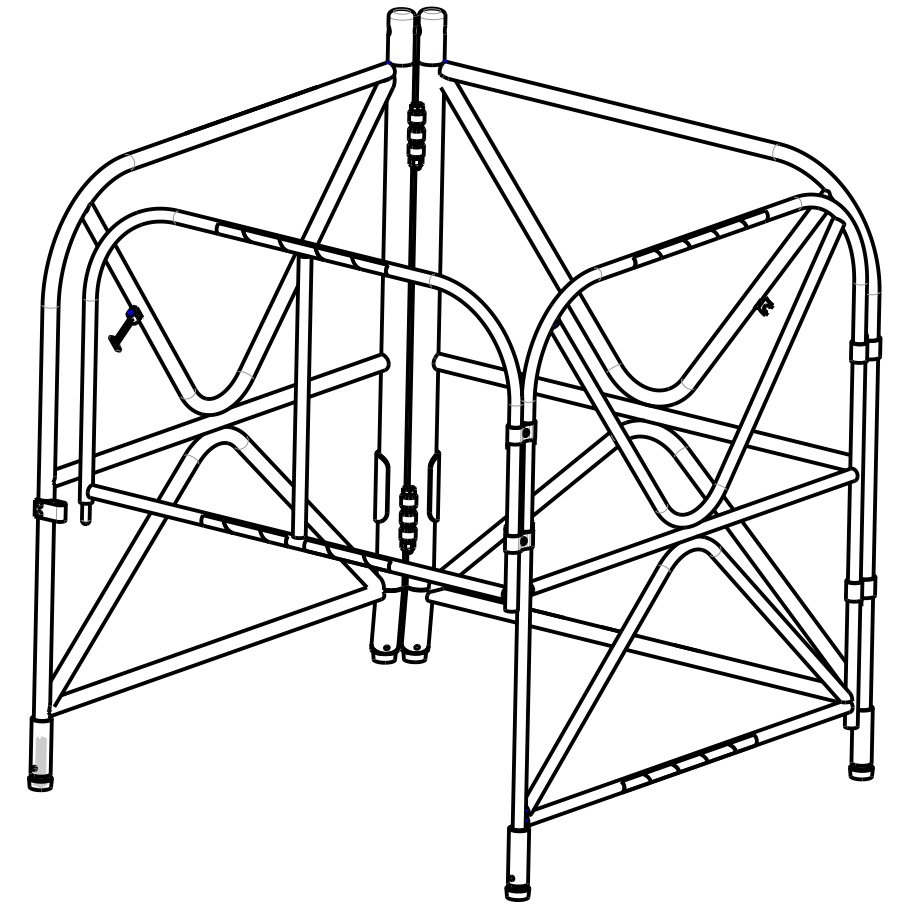

DETAIL A
SCALE 1:5

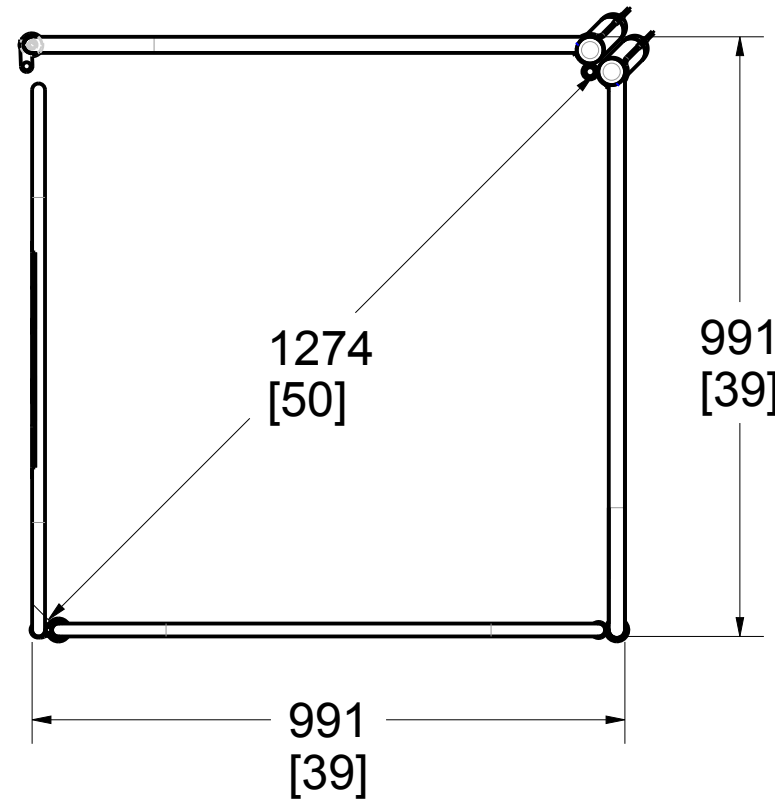
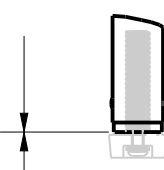

0
[0]
Min

51
[2]
Max

SEE DETAIL A

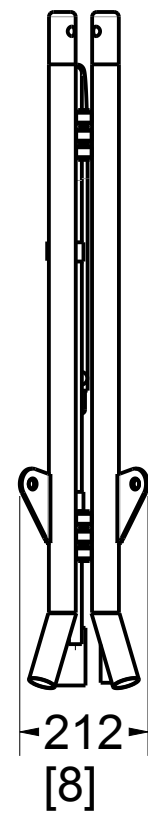
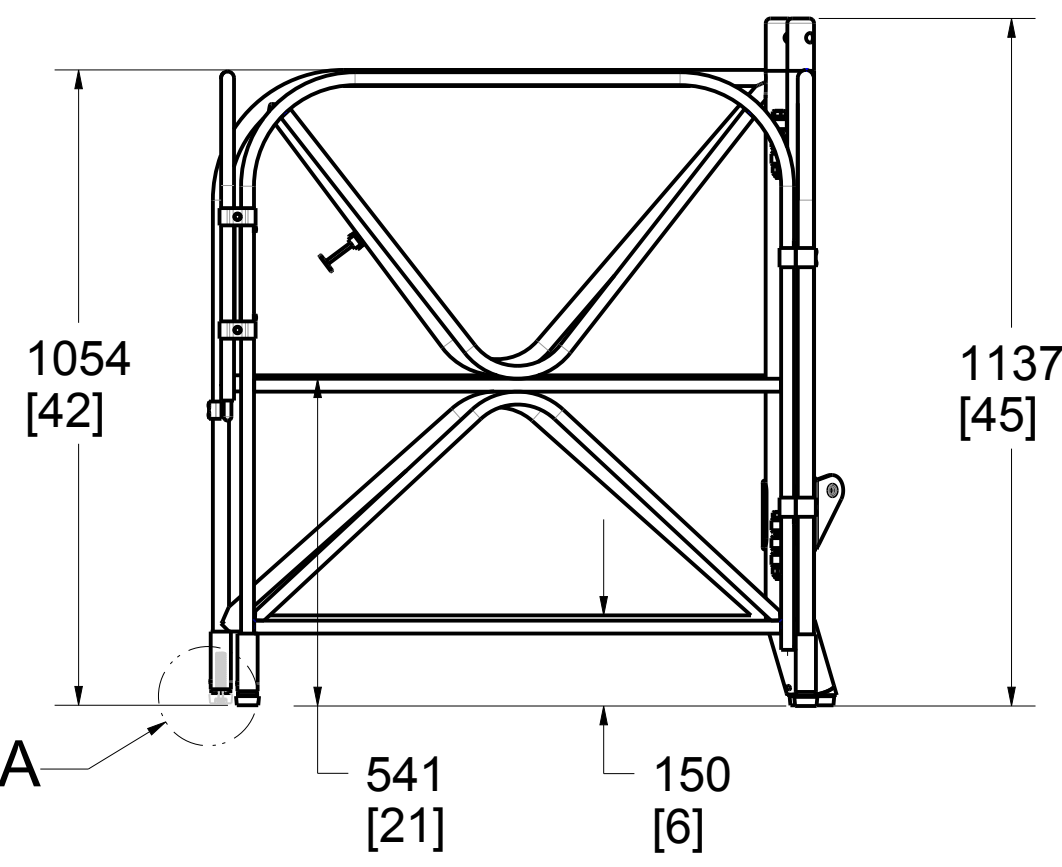

PAT.NO.:
CA 2.479.513
US 7,213,715 B2
EP 03 744 296.9



PRODUITS DE SERVICE PUBLICS INNOVA INC.
INNOVA PUBLIC UTILITY PRODUCTS INC.

© 9105-0732 QUEBEC INC. and under exclusive license to INNOVA PUBLIC UTILITY PRODUCTS INC., (hereafter « INNOVA »). All rights reserved. Protected under the Copyright Act of Canada and international treaties and agreements regarding copyrights. Violators are subject to prosecution and other legal recourses for infringement. Any reproduction, adaptation or other use or disclosure whatsoever, in totality or in part, and in any form or by any means whatsoever, strictly forbidden and requires the prior written approval of INNOVA. All data is the exclusive property of 9105-0732 QUEBEC INC. and under exclusive license to INNOVA and cannot be used nor disclosed in any way either without the prior written approval of INNOVA.

WEIGHT:	TITLE:			
33 Lb	Manhole guard with integrated mast 1067mm (42")			
15 Kg				

COLOR:	Material:	SHEET(S):	PROJET:	Rev.
Yellow XTIRPA	Aluminum	1 / 4	IN-2108	03

Important:
The load must be applied inside the perimeter of the manhole guard.

When used in a "V" configuration, the front opening must be secured or closed with a guard, a wall or any other means to secure the working area.

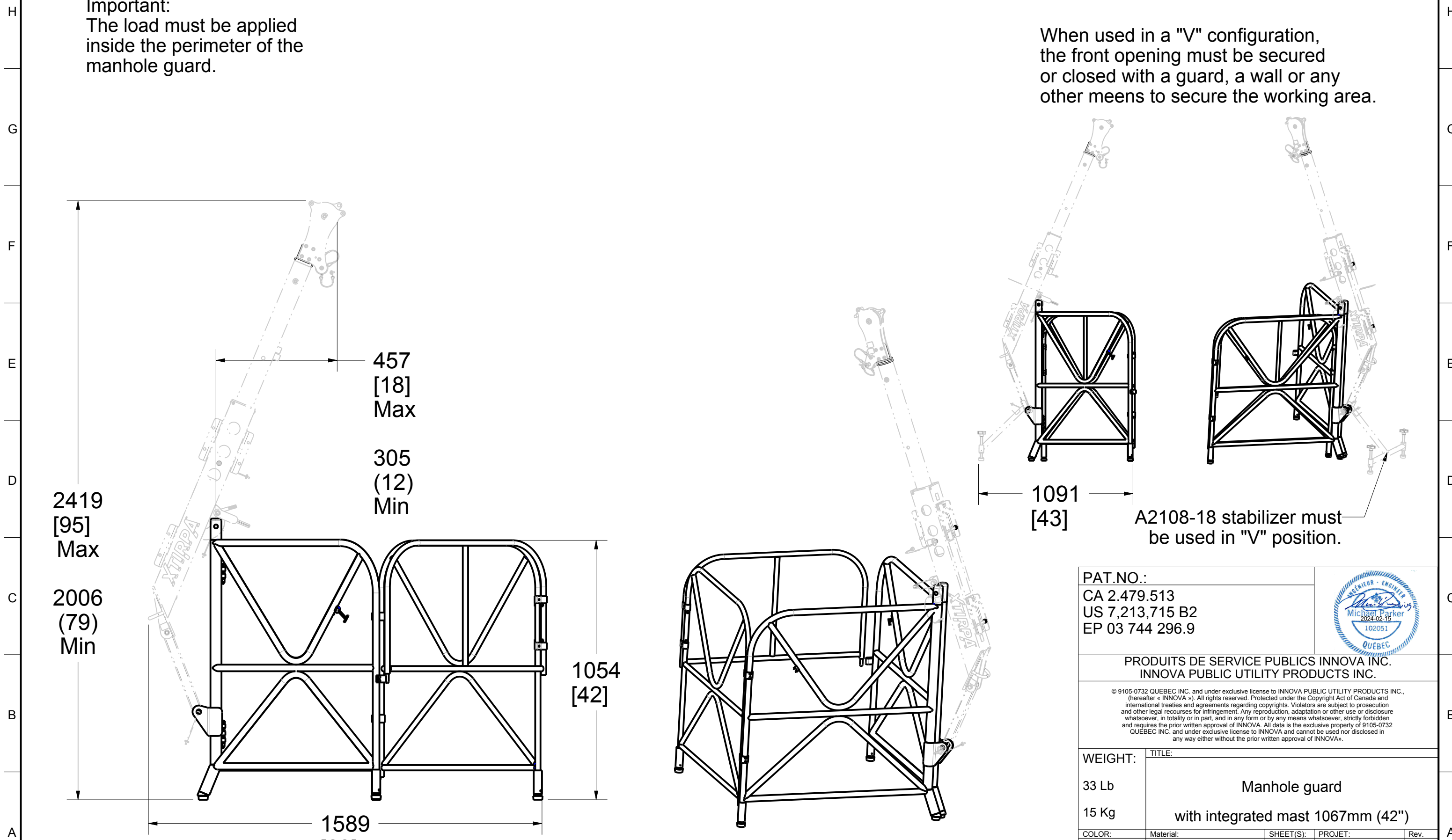

PAT.NO.:				
CA 2.479.513				
US 7,213,715 B2				
EP 03 744 296.9		PRODUITS DE SERVICE PUBLICS INNOVA INC. INNOVA PUBLIC UTILITY PRODUCTS INC.		
<small>© 9105-0732 QUEBEC INC. and under exclusive license to INNOVA PUBLIC UTILITY PRODUCTS INC., (hereafter « INNOVA »). All rights reserved. Protected under the Copyright Act of Canada and international treaties and agreements regarding copyrights. Violators are subject to prosecution and other legal recourses for infringement. Any reproduction, adaptation or other use or disclosure whatsoever, in totality or in part, and in any form or by any means whatsoever, strictly forbidden and requires the prior written approval of INNOVA. All data is the exclusive property of 9105-0732 QUEBEC INC. and under exclusive license to INNOVA and cannot be used nor disclosed in any way either without the prior written approval of INNOVA.</small>				
WEIGHT:	TITLE:			
33 Lb	Manhole guard with integrated mast 1067mm (42")			
15 Kg				
COLOR:	Material:	SHEET(S):	PROJET:	Rev.
Yellow XTIRPA	Aluminum	2 / 4	IN-2108	03

SPECIFICATIONS

This equipment is considered as part of a personal fall arrest system (PFAS) with a maximum working capacity of 190 Kg (420 lb).

It is only to be used in conjunction with a personal fall arrest system that limits the maximum arrest force (MAF).

Working Load (mass) :With Davit Arm IN-2002 or IN-2210: 190 kg (420 lb)
 Max Capacity without deformation:
 With Davit Arm fully extended IN-2002 or IN-2210 : 18,683 N (4,200 lbf)
 With Davit Arm IN-2002 or IN-2210 at Anchorage point : 22,295 N (5,000 lbf)
 Maximum Moment : 8,542 N-m (75,600 lbf-in).

STANDARDS

Name	Classification	Year	Users
AS / NZS 5532	Freefall arrest	2013	1
CSA Z259.15	AD	2022	1
OSHA 1910.66			1

MATERIAL AND CONSTRUCTION

Structural tubes : Structural Aluminum
 Hardware : Zinc plated steel Gr. 5 and stainless steel
 Finish : Yellow XTIRPA powder paint
 Welding certification: CSA W47.2M

RESTRICTIONS

This equipment is to be used only with products approved by Innova Public Utility Products Inc.

This equipment must always be operated on a level surface.

Ensure that all hardwares and connecting pins are properly installed before use.

In the occurrence of a fall or that the safety of the equipment is in doubt, the equipment must be immediately removed from service and inspected by qualified personnel before reuse.

Product number: **IN-2108**

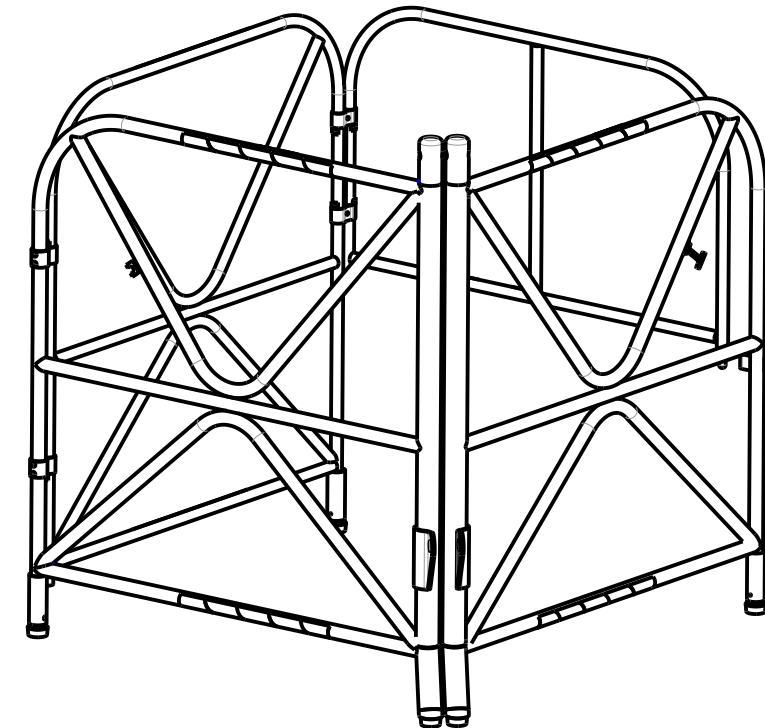

PAT.NO.:
 CA 2.479.513
 US 7,213,715 B2
 EP 03 744 296.9

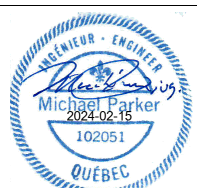

PRODUITS DE SERVICE PUBLICS INNOVA INC.
 INNOVA PUBLIC UTILITY PRODUCTS INC.

© 9105-0732 QUEBEC INC. and under exclusive license to INNOVA PUBLIC UTILITY PRODUCTS INC., (hereafter « INNOVA »). All rights reserved. Protected under the Copyright Act of Canada and international treaties and agreements regarding copyrights. Violators are subject to prosecution and other legal recourses for infringement. Any reproduction, adaptation or other use or disclosure whatsoever, in totality or in part, and in any form or by any means whatsoever, strictly forbidden and requires the prior written approval of INNOVA. All data is the exclusive property of 9105-0732 QUEBEC INC. and under exclusive license to INNOVA and cannot be used nor disclosed in any way either without the prior written approval of INNOVA».

WEIGHT:	TITLE:			
33 Lb	Manhole guard with integrated mast 1067mm (42")			
15 Kg				

COLOR:	Material:	SHEET(S):	PROJET:	Rev.
Yellow XTIRPA	Aluminum	3 / 4	IN-2108	03

Product number: IN-2108

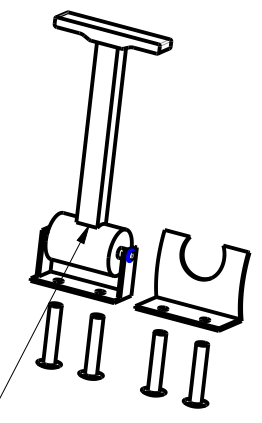
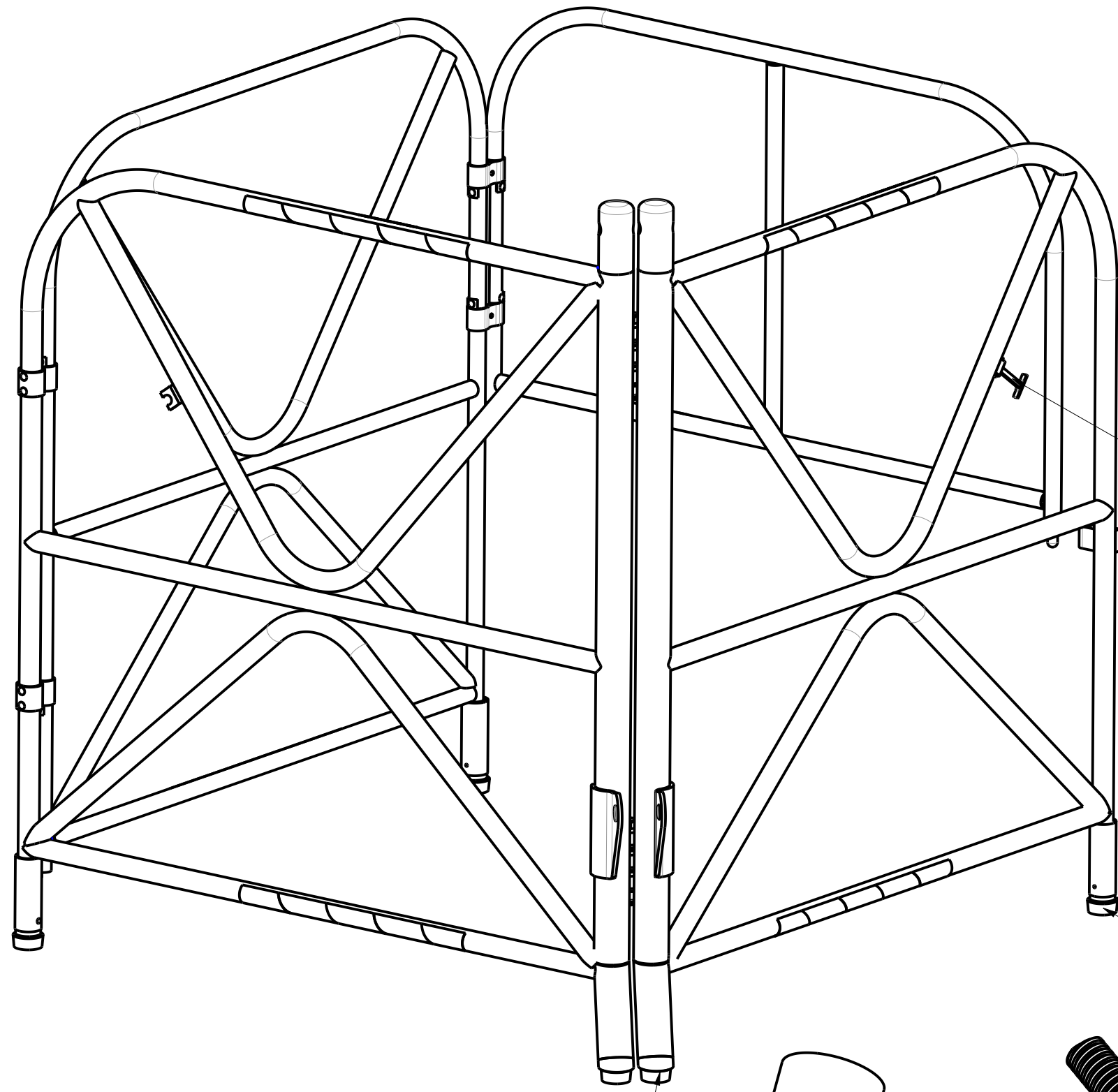

A2001-32

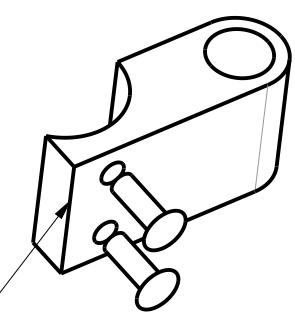

A2001-37

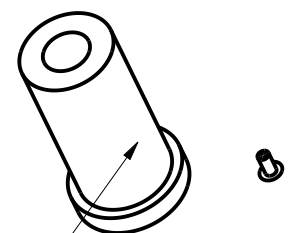

A2001-10
3X

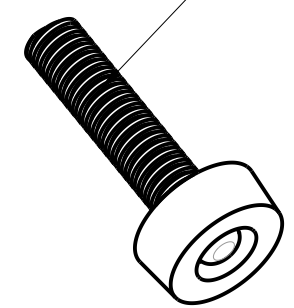

A2001-09
3X

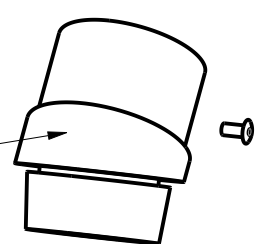

A2001-36
2X

PAT.NO.:
CA 2.479.513
US 7,213,715 B2
EP 03 744 296.9

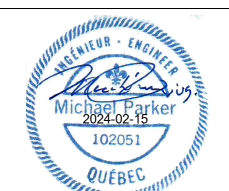

PRODUITS DE SERVICE PUBLICS INNOVA INC.
INNOVA PUBLIC UTILITY PRODUCTS INC.

© 9105-0732 QUEBEC INC. and under exclusive license to INNOVA PUBLIC UTILITY PRODUCTS INC., (hereafter « INNOVA »). All rights reserved. Protected under the Copyright Act of Canada and international treaties and agreements regarding copyrights. Violators are subject to prosecution and other legal recourses for infringement. Any reproduction, adaptation or other use or disclosure whatsoever, in totality or in part, and in any form or by any means whatsoever, strictly forbidden and requires the prior written approval of INNOVA. All data is the exclusive property of 9105-0732 QUEBEC INC. and under exclusive license to INNOVA and cannot be used nor disclosed in any way either without the prior written approval of INNOVA.

WEIGHT:	TITLE:			
33 Lb	Manhole guard with integrated mast 1067mm (42")			
15 Kg				

COLOR:	Material:	SHEET(S):	PROJET:	Rev.
Yellow XTIRPA	Aluminum	4 / 4	IN-2108	03