

# Electrical wire rope winches

## Electrical wire rope winch BETA SL

Short times to delivery are followed by long periods in operation: the electric wire rope winch BETA SL in its standard design works permanently reliably due to enclosed worm gear pairs or spur gears

with high-quality brake motors. The electric wire rope winches BETA SL are available with a contactor control system including a gear limit switch.

### Equipment

- Maintenance-free worm gear pairs or low-maintenance spur gear with milled and ground gears – running in oil bath
- Very quiet running by diagonal interlock
- Electrically released spring-applied disk brake
- Duty ratio S3 – 40 %
- Range of temperature: -20 °C – +40 °C
- Powerful three-phase motor for multi-range voltage 380 – 420 V / 50 Hz or 440 – 460 V / 60 Hz
- Motor protection type IP 55
- Grooved rope drum
- Large wire rope capacity
- Contactor control 42 V
- Gear limit switch
- Electronic overload protection as of 1000 kg lifting load
- According to the accident prevention provisions DGUV V54 (BGV D8)

### Options selectable

### Options

Size	Capacity	Control	Mechanical
SL0	250 kg	Control pendant	./.
SL1	500/630 kg	Control pendant or frequency converter	Pressure roller or slack rope switch, alternatively combination of pressure roller and slack-rope switch
SL2	980/1250 kg	Control pendant or frequency converter	Pressure roller or slack rope switch, alternatively combination of pressure roller and slack-rope switch
SL3	2000 kg	Control pendant or frequency converter	Pressure roller or slack rope switch, alternatively combination of pressure roller and slack-rope switch

Delivery time for versions control pendant, pressure roller or slack rope switch approx. 10 days

Delivery time for version frequency converter approx. 25 days



Option: pressure roller



Option: slack rope switch



Option: control pendant



Option: frequency converter



BETA SLO



BETA SL1 – SL3

# Electrical wire rope winches

## Electrical wire rope winch BETA SL

### Technical data

Art. no.	Size	Capacity 1 <sup>st</sup> layer	Rope speed	FEM	BGV	Voltage	Power	Rope Ø*	Rope capacity 1 <sup>st</sup> layer	Rope capacity top layer	A	B	C Ø	F	G	H	L	M Ø	Weight
		[kg]	[m/min]			[V]	[kW]	[mm]	[m]	[m]	[mm]	[mm]	[mm]	[mm]	[mm]	[mm]	[mm]	[mm]	[kg]
	Type code																		
40063758	SL0	250	2.5	1 Bm	D8	400V	0.25	4	7	46.7	185	170	12	488	469**	243	180	64	22
31140006	SL0	250	5.0	1 Bm	D8	400V	0.37	4	7	46.7	185	170	12	488	469**	243	180	64	22
40062946	SL1	500	7.1	1 Bm	D8	400V	0.75	6	6.7	48.9	215	300	13.5	751	340	319	200	86	64
40062989	SL1	630	7.1	1 Bm	D8	400V	0.75	6	6.7	48.9	215	300	13.5	751	340	319	200	86	64
40062990	SL2	980	6.3	1 Am	D8	400V	1.1	9	11	77.5	270	400	18	937	465	487	250	175	119
40062993	SL2	1250	6.3	1 Am	D8	400V	1.1	9	11	77.5	270	400	18	937	465	487	250	175	119
40062996	SL3	2000	6.8	1 Bm	D8	400V	2.2	12	9.8	73.8	320	510	22	1096	570	599	300	175	207

\*recommended rope: DIN 3069 FE-znk-1960 sZ-spa

\*\*Size SLO to motor fan over (worm gear)

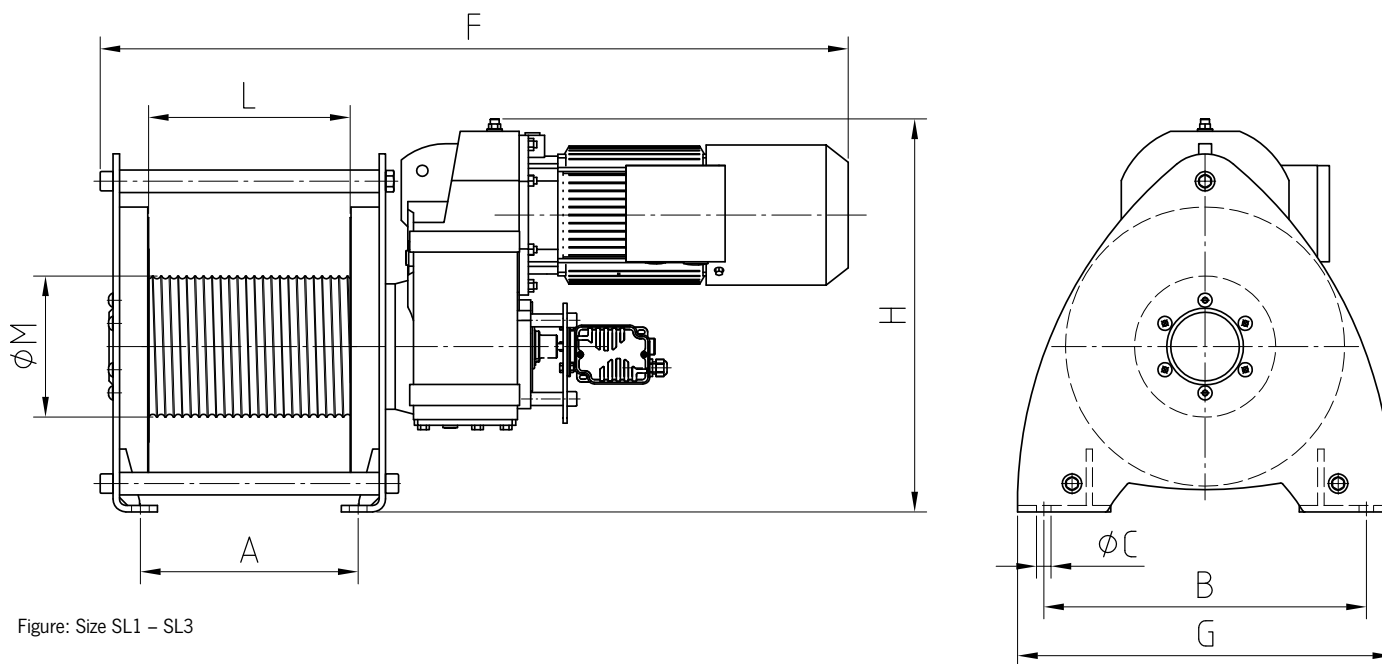

Figure: Size SL1 – SL3

CAD & go

